

## **Yanmar** Air-Cooled Diesel Powered *Sandy & Muddy Water Handling Heavy Duty QP Trash Pump*

# QP-301TD

80mm  
**3** inch

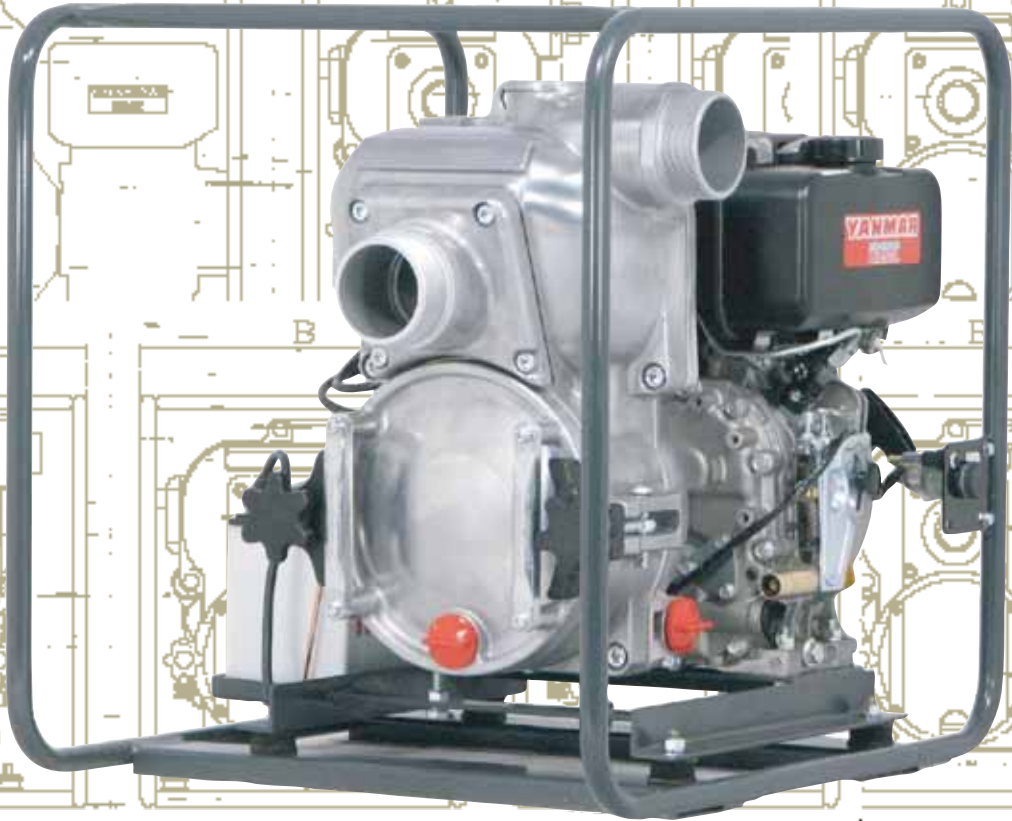

50mm  
**2** inch

## QP-203TD



- ★ *Matsusaka Trash Pumps are designed and engineered for heavy duty use required by professional contractors.*
- ★ *Large cleanout cover makes easy access without removing suction hoses.*
- ★ *Impeller & seal or inner components adopted are durable for dewatering applications.*



## ■ Specification [Yanmar Air Cooled Diesel Driven QP Trash Pump]

Model	QP-203TD	QP-301TD
Engine	L48N	L70V
Suction x Discharge(dia-mm)	50 × 50	80 × 80
Max head(m)	27	24
Max Flow (l/minute)	600	1000
Dry Weight(kgs)	64	66
Engine Max Output(PS)	4.7	6.5

\*Specification may be changed without prior to notice!

## ■ Pump Performance Curve

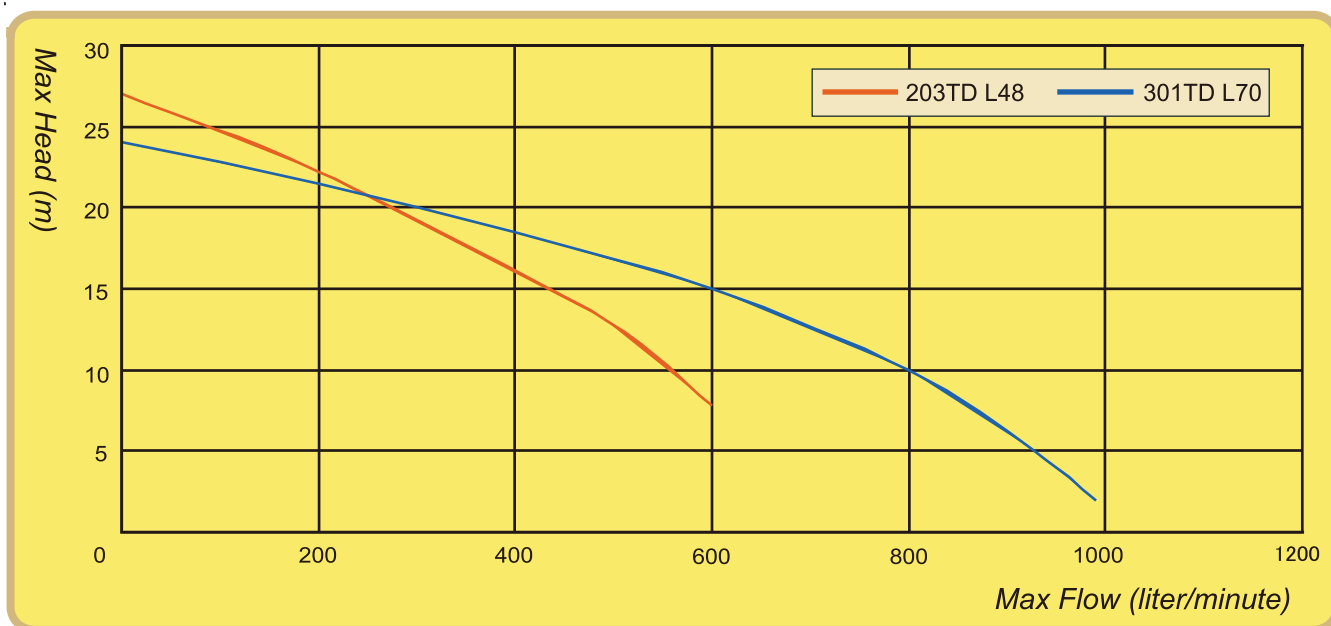

## ■ Outer Dimension

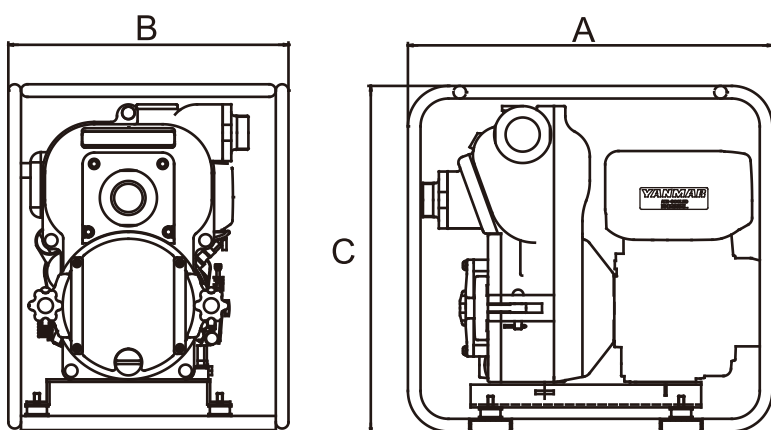

Pump	mm	mm		
		A	B	C
QP-203TD L48N		640	490	610
QP-301TD L70V		665	445	660



Manufactured by:



**MATSUSAKA ENGINEERING CO., LTD.**

Homepage <http://www.qp-pump.com>



Head 23, Kanda-Matsunaga cho, Chiyoda ku, Tokyo, Japan  
office TEL: +81-3-3257-6130 FAX: +81-3-3257-6129



Plant 2155, Nonaka, Taki cho, Taki gun, Mie-pref, Japan  
TEL: +81-598-39-3211 FAX: +81-598-39-3844

Distributed by: