

HONDA engine driven *Matsusaka*

3 inch - 4 inch

Push water higher & further!



305S



305SL



402S



402SX



QP-Z



T405SLT



MATSUSAKA ENGINEERING CO., LTD.

▶▶▶ Specifications [Honda Air-cooled Gasoline Engine driven QP High pressure Pump]

MODEL	QP-305S	QP-305SL	QP-Z	QP-402S	QP-402SL	QP-402SX	QP-T405SLT
Engine Type	GX160	GX240	GX620	GX240	GX390	GX390	GX390
Inlet dia. × Outlet dia. (mm)	80 × 80	80 × 80	80 × 80	100 × 100	100 × 100	100 × 100	100 × 100
Max. Head (m)	70	65	100	50	50	70	115
Max. Capacity (L/min.)	480	550	850	1200	1400	750	795
Net Weight (kg)	29	42	200	59	70	70	127
Engine Net Power (PS)	4.9	7.2	18.4	7.2	11.1	11.1	11.1

Specification may be changed without prior notice !

▶▶▶ Performance curves

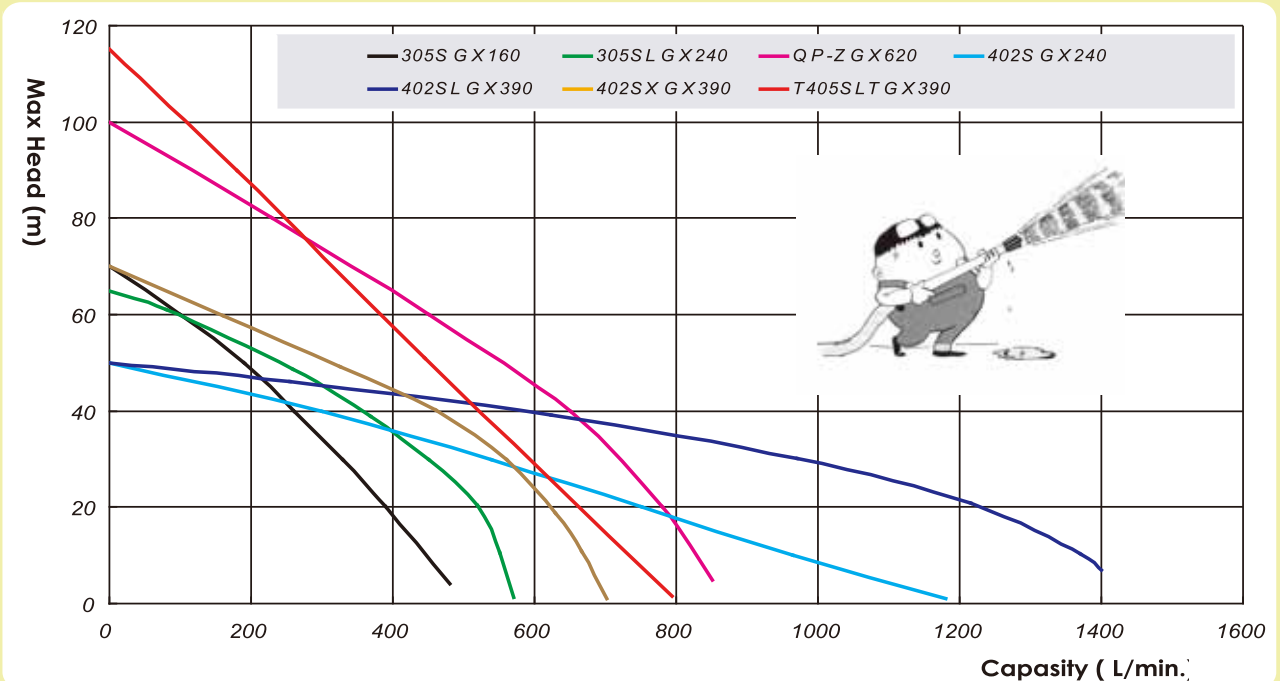

▶▶▶ Outer Dimensions

A wheel & tyres shown available at option !

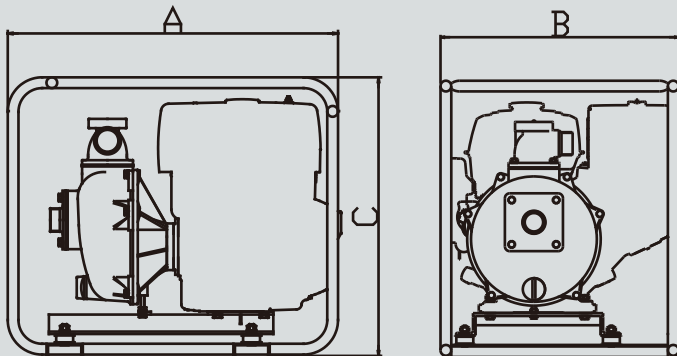

MODEL		mm		
		A	B	C
QP-305S	GX160	523	386	460
QP-305SL	GX240	622	454	560
QP-Z	GX620	1057	592	853
QP-402S	GX240	670	466	605
QP-402SL	GX390	722	500	608
QP-402SX	GX390	722	500	608
QP-T405SLT	GX390	914	711	812



Manufactured by:

MATSUSAKA ENGINEERING CO., LTD.

Q048

<http://www.qp-pump.com>



Head office 23, Kanda-Matsunaga cho, Chiyoda ku, Tokyo, Japan
 TEL: +81-3-3257-6130 FAX: +81-3-3257-6129
 Factory 2155, Nonaka, Taki cho, Taki gun, Mie-pref, Japan
 TEL: +81-598-39-3211 FAX: +81-598-39-3844

Distributed by: