

HONDA *engine driven* **Matsusaka**
3 inch - 4 inch
Push water higher & further!

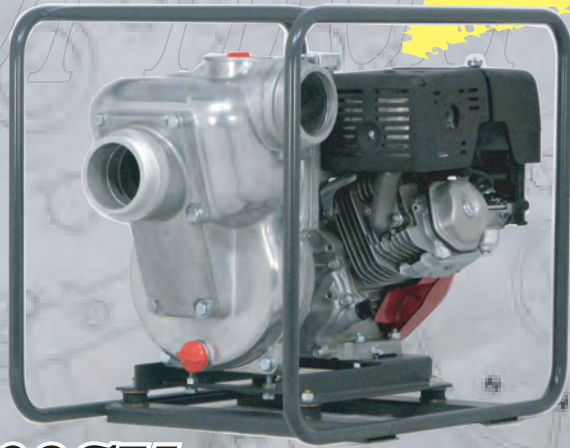

402SX

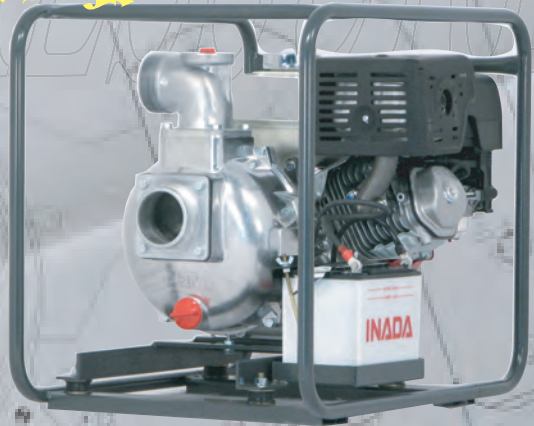

305SL

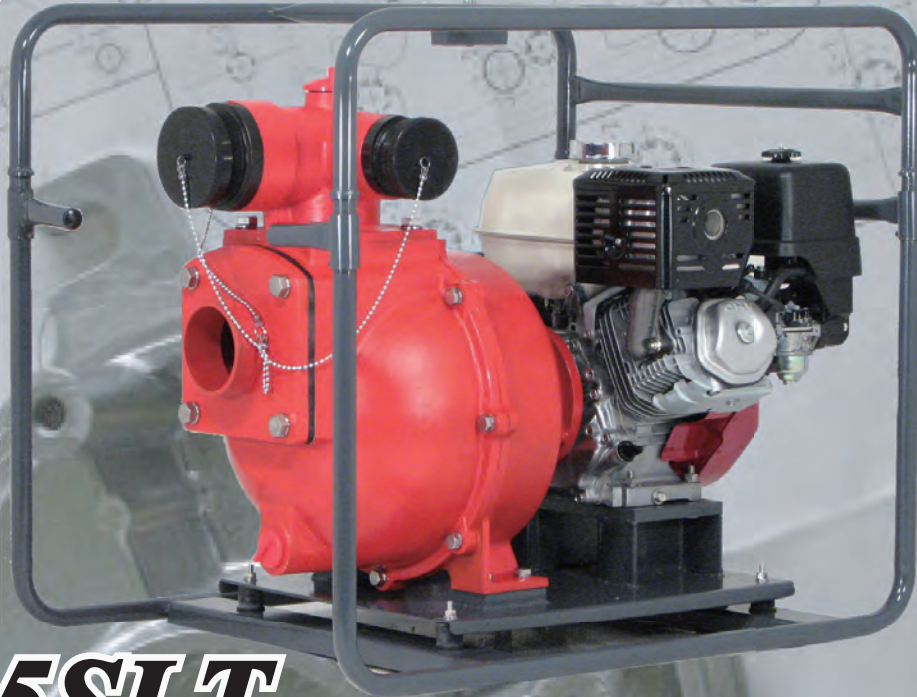

T405SLT

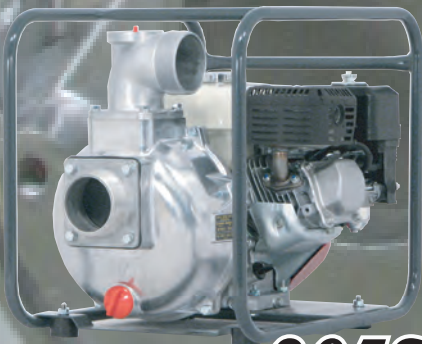

305S

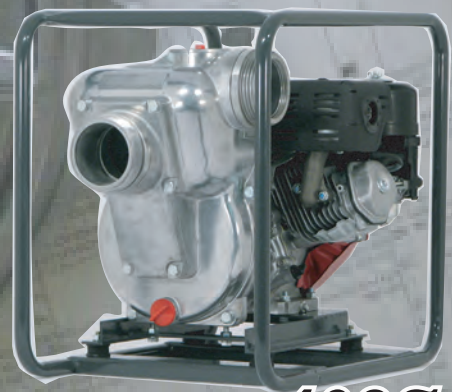

402S



▶▶▶ Specifications [Honda Air-cooled Gasoline Engine driven QP High pressure Pump]

MODEL	QP-305S	QP-305SL	QP-402S	QP-402SL	QP-402SX	QP-T405SLT
Engine Type	GX160	GX240	GX240	GX390	GX390	GX390
Inlet dia. × Outlet dia. (mm)	80 × 80	80 × 80	100 × 100	100 × 100	100 × 100	100 × 100
Max. Head (m)	70	65	50	50	70	115
Max. Capacity (L/min.)	480	550	1200	1400	1050	795
Net Weight (kg)	29	42	59	70	70	127
Engine Net Power (PS)	4.9	8.0	8.0	11.8	11.8	11.8

Specification may be changed without prior notice !

▶▶▶ Performance curves

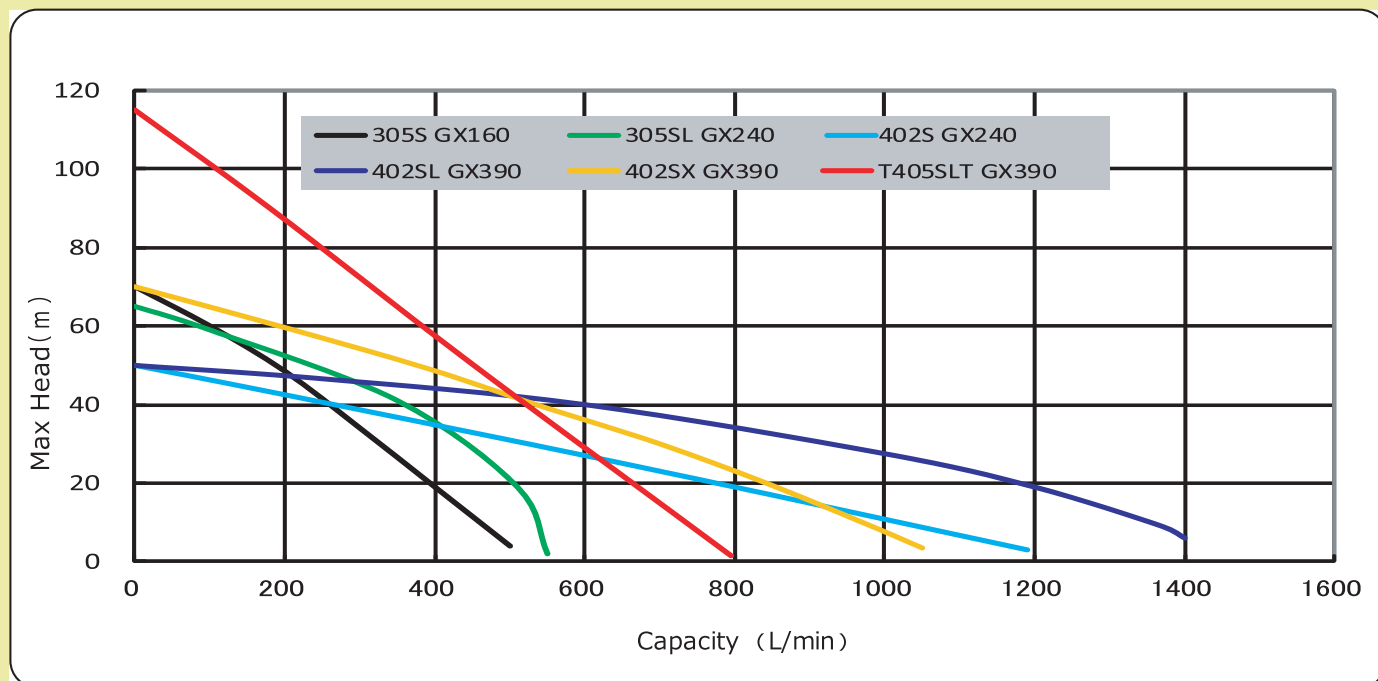

▶▶▶ Outer Dimensions

A wheel & tyres shown available at option !

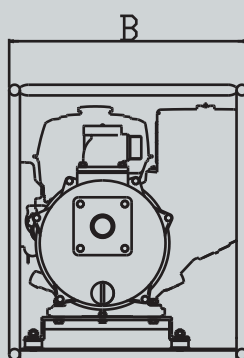
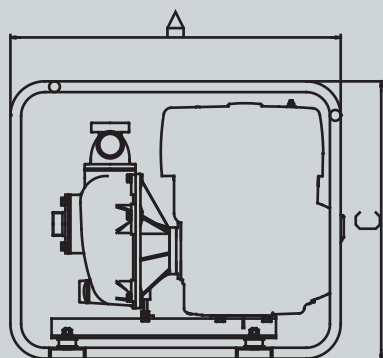

MODEL		mm		
		A	B	C
QP-305S	GX160	523	386	460
QP-305SL	GX240	622	454	560
QP-402S	GX240	670	466	605
QP-402SL	GX390	722	500	608
QP-402SX	GX390	722	500	608
QP-T405SLT	GX390	914	711	812

Manufactured by:
MATSUSAKA ENGINEERING CO., LTD.

<http://www.qp-pump.com>

Head 23, Kanda-Matsunaga cho, Chiyoda ku, Tokyo, Japan
Office TEL: +81-3-3257-6130 FAX: +81-3-3257-6129

Plant 2155, Nonaka, Taki cho, Taki gun, Mie-pref, Japan
TEL: +81-598-39-3211 FAX: +81-598-39-3131



Distributed By: